

Chapter

2

Understanding

Flow

www.polyethylene.ir  
دانش لوله پلی اتیلن

Orin Bennett

## UNDERSTANDING FLOW

The process of designing drainage facilities, including culverts and pipelines, consists of two distinct functions. The engineer must determine the maximum volume of flow to be transported by the drainage facility, and the type and size of drainage structure that will transport that maximum volume of flow.

Many different procedures are available to determine design flow and to size drainage structures. Numerous texts and manuals have been developed to guide the design engineer. In addition many agencies for which drainage facilities are being designed have developed standard procedures for hydrologic analysis and drainage structure design. Because, quite properly, practice varies from state to state and often within states, this chapter is not intended to serve the full function of a design manual, but rather it is intended to identify procedures for determining design flow and for sizing drainage structures. A description of various flow and pipe sizing methodologies is provided; manuals or texts that include detailed design procedures are referenced.

### Flow in Storm Water Conveyances

As a watershed begins to accept precipitation, surface vegetation and depressions intercept and retain a portion of that precipitation. Interception, depression storage and soil moisture each contribute to groundwater accretion, which constitutes the basin recharge. Precipitation that does not contribute to basin recharge is direct runoff. Direct runoff consists of surface runoff (overland flow) and subsurface runoff (interflow), which flows into surface streams. The basin recharge rate is at its maximum at the beginning of a storm, and decreases as the storm progresses.

The method of the United States Soil Conservation Service (SCS) for the calculation of runoff breaks down basin recharge into two parts, initial interception and infiltration. A typical direct runoff history diagram (or hydrograph) is presented in Fig 2.1. The shape of the hydrograph is different from basin to basin. It is a function of the physical characteristics of the drainage basin, rainfall intensities and distribution pattern, land uses, soil type and the initial moisture condition of the soil.

**Figure 2-1**

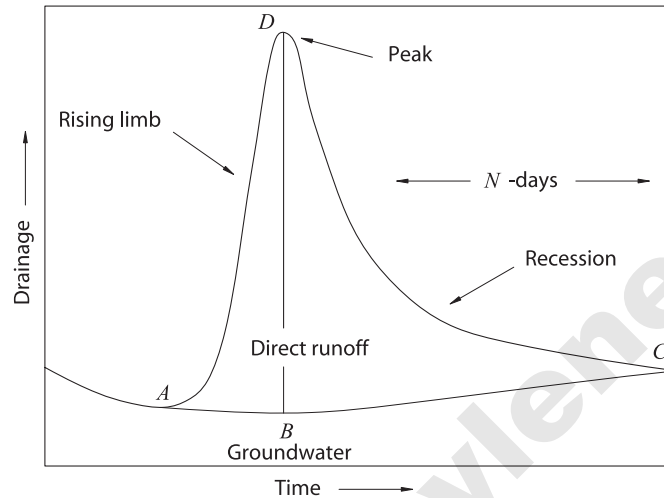

**Figure 2-1: Typical Runoff Hydrograph**

Direct runoff is precipitation minus basin recharge (sum of initial interception and infiltration) and is depicted by the area under the hydrograph above the groundwater base flow, ABC.

Runoff volume, which varies directly with basin precipitation, is often taken as the precipitation modified by a coefficient reflecting basin recharge. That is,

$$R = CP \quad \text{Equation 2-1}$$

Where:

R = runoff volume, cf

C = runoff coefficient

P = precipitation, in.

An efficient estimate of the runoff coefficient C is very critical for computing the conversion of rainfall to runoff. The runoff coefficient is discussed in more detail later in this chapter.

Several methods are available for computing the peak rate of storm runoff. Three commonly used methods are explored in this chapter: the Rational Method, the SCS Technical Release 55 (TR-55) method and the Hydraulic Engineering Center (HEC) computer modeling method. The Rational Method, the method of choice in many jurisdictions, requires subjective engineering judgement for the interpretation and specification of input variables. The TR55 method is less vulnerable to subjective judgment. The HEC computer modeling method is widely used and provides for detailed watershed evaluation.

Consider that there are three levels of determining maximum flow for a drainage facility. For small drainage shed areas of ordinary importance, the Rational Method with appropriate engineering judgments provides adequate design information. Larger drainage shed areas (greater than 100 acres) with a drainage conveyance facility of greater importance demands a more realistic storm evaluation, which includes a method of considering basin infiltration, basin recharge and the ability to consider subshed areas. Much larger and complex watershed areas containing subshed areas with different characteristics and where routing between subshed areas is a consideration may require the more complex modeling method found with the Hydraulic Engineering Center computer models.

### **The Rational Method**

For storage related design issues, it is necessary to determine total runoff volume from a basin over a given period of time. For the design of most storm water conveyances, it is sufficient to determine the instantaneous peak rate of flow due to a specified storm event. The Rational Method is useful to calculate the peak rate of flow at a specific collecting point of a drainage basin. This method was first employed in Ireland in urban storm sewer designs by Mulvaney in 1847. The use of this method is still recommended by many engineers for small watersheds (less than 100 acres).

To calculate the peak rate of flow:

$$Q_p = CC_f i A \quad \text{Equation 2-2}$$

Where:

- $Q_p$  = the peak rate of flow, cfs
- $C$  = the runoff coefficient = (runoff)/(rainfall)
- $C_f$  = the frequency factor ranging from 1 to 1.25 for a return period from 1 to 100 years
- $i$  = the average rainfall intensity during the storm duration time period, in/hr
- $A$  = the basin area, acres

The equation may also be expressed in this form:

$$Q_p = 640 C C_f i A \quad \text{Equation 2-3}$$

Where:

- $Q_p$  = peak rate of flow, cfs
- $i$  = average rainfall intensity during the storm duration time period, in/hr
- $A$  = basin area, miles<sup>2</sup>

Note: Some regions may have  $C_f$  incorporated into  $C$ , in which case  $C_f$  would not appear in the above equation.

### **Watershed Area, A**

The basin (watershed) area for a drainage basin is that surface area contributing runoff to a specified collection point. Topographic information is used to determine the boundaries of the contributing surface area. For urbanized areas topographic information may come from residential subdivision or commercial and industrial development improvement plans. For undeveloped areas topographic surveys of the watershed may be available or can be developed by various surveying and mapping techniques. For large areas it is common to use United States Geological Survey (USGS) quadrangle sheets as a reliable source of topographic information. It is often necessary to develop sub-watersheds within the primary watershed being considered. Each sub-watershed will have its own shed area, time of concentration and rainfall intensity.

The smaller and more impervious the watershed area, the more accurate the results of the Rational Method (Equation 2.2) becomes. The larger the watershed area, the longer the flow channel and, therefore, the longer the time of concentration and the lesser the likelihood of a uniform intensity of rainfall throughout. One hundred acres is often taken as the upper limit of watershed area when using the Rational Method.

### **Intensity, i**

The rainfall intensity,  $i$ , is dependent upon the duration of rainfall and the frequency of the storm event or the Return Period. Short duration storms and storms of longer return periods are often more intense than longer, frequent storms. Rainfall intensity/duration/frequency (IDF) curves are developed from historically collected rainfall data from rain gauge recordings. Information gathered at a rain gauge site can be considered representative of 10 square miles of drainage area that is expected to experience uniform meteorological conditions. The IDF curve at the Sacramento California International Airport is shown in Figure 2.2.

**Figure 2-2**

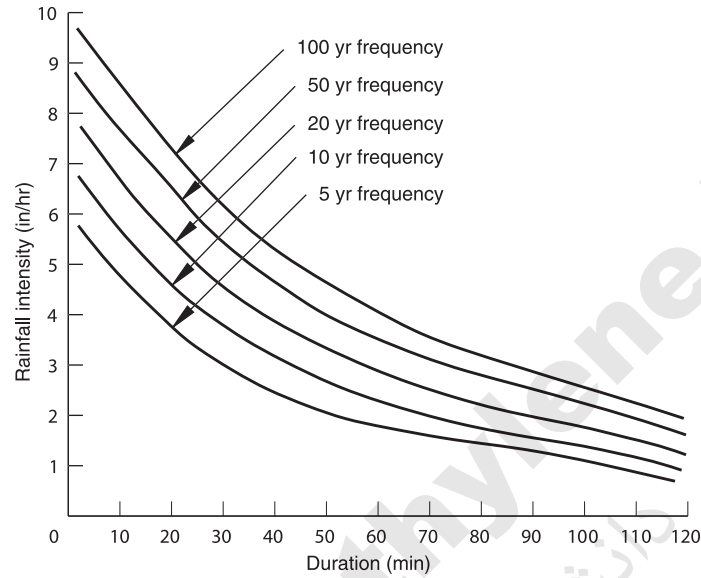

**Figure 2-2: Intensity Duration Frequency Curve at the Sacramento, California International Airport**

IDF curves are available from the National Weather Service, most State Departments of Transportation, local flood control agencies, and other governmental agencies. For application in the Rational Method, probable maximum values for a specific design storm frequency, or return period, are used to provide the maximum design rate of flow for sizing storm conveyance facilities. Typical return period design criteria for storm water conveyance and control structures are given in Table 2.1. Most local agencies have developed standards that specify the return period design requirement for storm water conveyance facilities within their jurisdiction. Most also have modified IDF curves set up with large factors of safety for establishing the design flow.

**Table 2-1**

Type of structure	Return Period Used for Design (years)
<b>Highway culverts</b>	
Low traffic	5 – 10
Intermediate traffic	10 – 25
High traffic	50 – 100
<b>Highway Bridges</b>	
Secondary system	10 – 50
Primary system	50 – 100
<b>Farm drainage</b>	
Culverts	5 – 50
Ditches	5 – 50
<b>Urban drainage</b>	
Storm sewers in small cities	2 – 25
Storm sewers in large cities	25 – 50
<b>Airfields</b>	
Low traffic	5 – 10
Intermediate traffic	10 – 25
High traffic	50 – 100
<b>Levees</b>	
On farms	2–50
Around cities	50–200
<b>Dams with no likelihood of loss of life</b>	
Small dams	50–100
Intermediate dams	100+
Large dams	–

**Table 2-1: Typical Design Return Period****Frequency Factor,  $C_f$** 

For storms with a frequency or return period of 10 years or less,  $C_f$  is unity.

However, for storms of higher return periods, rainfall intensity increases, infiltration and other losses are reduced, and  $C_f$  increases. Table 2.2 lists  $C_f$  values for various storm frequencies.

**Table 2-2**

Return Period (years)	$C_f$
$\leq 10$	1.0
25	1.1
50	1.2
100	1.25

**Table 2-2: Frequency Factor,  $C_f$** **Runoff Coefficient, C**

Many factors or variables affect the magnitude of runoff coefficient, C. These include slope of the ground, type of ground cover, soil moisture, travel length and velocity of overland flow, travel length and velocity of stream flow, rainfall intensity and other phenomena. However, effects on the runoff coefficient are dominated by the type of ground surface and it is that variable that establishes the value of C. The engineer responsible for the design of highway and other drainage facilities must anticipate and assess the most likely effects of future development of all the land in the watershed of interest. Increasing volumes of storm runoff due to reduced infiltration and greater peak discharges due to decreased travel time attend increasing urbanization. The coefficients in Table 2.3 reflect expected surface conditions upon buildout of the watershed.



**Table 2-3**

<b>Type of Development</b>	<b>Values of C</b>
Urban business	0.70-0.95
Commercial office	0.50-0.70
Residential development	
Single-family homes	0.30-0.50
Condominiums	0.40-0.60
Apartments	0.60-0.80
Suburban residential	0.25-0.40
Industrial development	
Light industry	0.50-0.80
Heavy industry	0.60-0.90
Parks, greenbelts, cemeteries	0.10-0.30
Railroad yards, playgrounds	0.20-0.40
Unimproved grassland or pasture	0.10-0.30
<b>Type of Surface Area</b>	<b>Values of C</b>
Asphalt or concrete pavement	0.70-0.95
Brick paving	0.70-0.80
Roofs of buildings	0.80-0.95
Grass-covered sandy soil	
Slopes 2% or less	0.05-0.10
Slopes 2% to 8%	0.10-0.16
Slopes over 8%	0.16-0.20
Grass-covered clay soils	
Slopes 2% or less	0.10-0.16
Slopes 2% to 8%	0.17-0.25
Slopes over 8%	0.26-0.36

**Table 2-3: Values of C for Ground Surfaces**

For the Rational Method, rainfall intensity is assumed to be consistent. For an actual storm event, the *design rainfall intensity* may occur at the beginning or at the end of the duration of a storm. The *antecedent rainfall* is the volume of rainfall that occurs from the beginning of rainfall to the occurrence of the design rainfall intensity. It is a common practice to assume C does not vary through the duration of a storm. Mitci developed the following relationship to determine the runoff coefficient, C:

$$C = \frac{0.98t}{4.54 + t}(P) + \frac{0.78t}{31.17 + t}(1-P) \quad \text{Equation 2-4}$$

Where:

- C = the runoff coefficient which has been correlated to the antecedent rainfall
- t = time, in minutes, from the beginning of the rainfall to the end of the design intensity rainfall
- P = the percent of impervious surface

### Time of Concentration, $t_c$

If rainfall were applied at a constant rate to an impervious surface, the runoff from the surface would eventually equal the rate of rainfall. The time required to reach that condition of equilibrium is the *time of concentration*,  $t_c$ , the travel time of a water particle from the hydrologically most remote point in a drainage basin to a specified collection point. If the rainfall duration time is greater than or equal to  $t_c$ , then every part of the drainage area is assumed to contribute to the direct runoff at the collection point.  $t_c$  is used as the design storm duration time.

Rainfall intensity for the Rational Method is assumed to be constant. If the duration of the storm is less than  $t_c$ , peak runoff will be less than if the duration is equal to  $t_c$ . For storms of duration longer than  $t_c$ , the runoff rate will not increase further. Therefore, the peak runoff rate is computed with the storm duration equal to  $t_c$ . Actual rainfall is not constant and this simplifying assumption is a weakness of the Rational Method.

Water moves through a watershed in some combination of sheet flow, shallow concentrated flow, stream flow and flow within storm drainage structures (pipes, canals, etc.). There are many ways to estimate  $t_c$ ; formulas exist for predictions of overland and channel flow. Time of concentration is the total time for water to move through each flow regime until it reaches the collection point.

The time of concentration of overland flow may be estimated from the Kirpich equation:

$$t_c = 0.00013 L^{0.77} S^{-0.385} \quad \text{Equation 2-5}$$

Where:

- $t_c$  = concentration time, hrs
- L = the longest length of water travel, ft
- S = ground surface slope =  $\frac{H}{L}$
- H = Difference in elevation between the most remote point on the basin and the collection point, ft.

The Kirpich empirical equation is normally used for natural drainage basins with well-defined overland flow routes along bare soil. For overland flow on impervious surfaces, the  $t_c$  obtained should be reduced by 60%. For overland flow on grass surfaces, the computed  $t_c$  should be increased by 100%.

The Upland Method is a graphical solution for finding the average overland flow velocity and can be used for overland flow in basins with a variety of land covers. This method relates  $t_c$  to the basin slope and to the length and type of ground cover. A graphical solution for finding the average overland flow velocity can be obtained from Figure 2.3. The time of concentration,  $t_c$ , is commonly taken as the longest length of flow travel divided by the average velocity of flow.

**Figure 2-3**

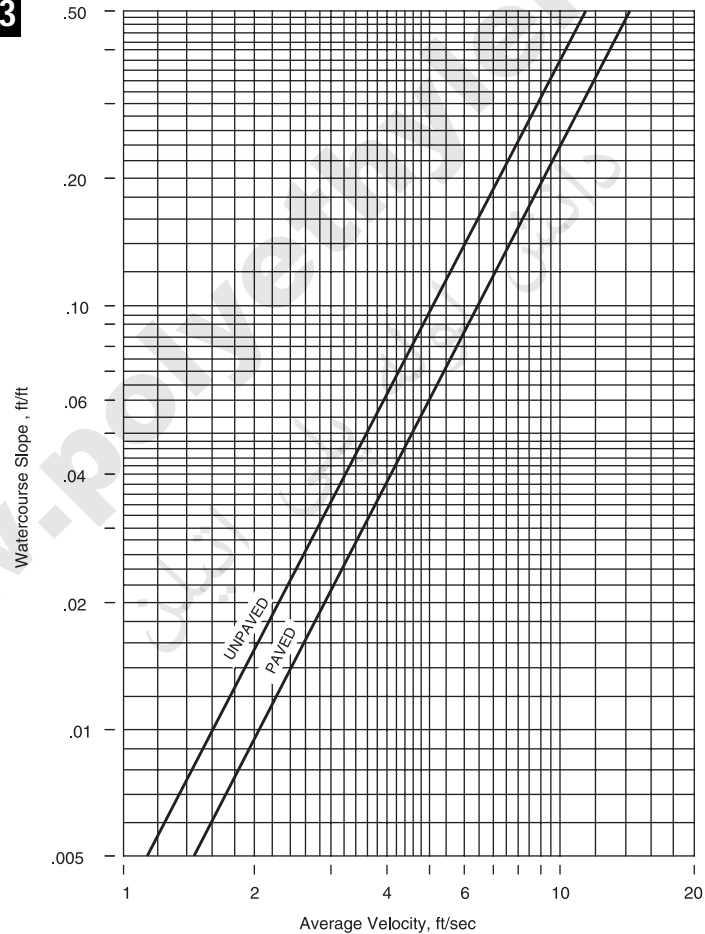

**Figure 2-3: Average velocities for estimating travel time for shallow concentrated flow (U.S. Soil Conservation Service Technical Release 55)**

For small drainage areas without a defined channel and from which runoff behaves as a thin sheet of overland flow, the Izzard formula (Equation 2.6) can be used for estimating the concentration time,  $t_c$ , where  $iL < 500$ :

$$t_c = \frac{4iL^{1/3}}{i^{2/3}} \left[ \frac{0.0007i + K}{S^{1/3}} \right] \quad \text{Equation 2-6}$$

Where:

- $t_c$  = concentration time, min
- $L$  = length of overland flow travel, ft
- $i$  = rainfall intensity, inches/hour
- $S$  = slope of ground surface, ft/100 ft
- $K$  = retardance coefficient

Values of retardance coefficient,  $K$ :

- 0.007 = for smooth asphalt surface
- 0.012 = for concrete pavement
- 0.017 = for tar and gravel pavement
- 0.046 = for closely clipped sod
- 0.60 = for dense blue grass turf

For sheet flow of less than 300 feet, Manning's kinematic solution can be used to compute  $T_t$ :

$$T_t = \frac{0.007(nL)^{0.8}}{(P_2)0.5 S^{0.4}} \quad \text{Equation 2-7}$$

Where:

- $T_t$  = travel time, hours
- $n$  = Manning's roughness coefficient (Table 2-4)
- $L$  = flow length, ft
- $P_2$  = 2-year, 24-hour rainfall, in
- $S$  = slope of hydraulic grade line (land slope), ft/100 ft

**Table 2-4**

Description	Typical Values
<b>Open channel, earth, uniform section</b>	
With short grass, few weeds	0.022-0.027
In gravelly soils, uniform section, clean	0.022-0.025
<b>Open channel, earth, fairly uniform section</b>	
No vegetation	0.022-0.025
Grass, some weeds	0.025-0.030
Dense weeds or aquatic plants in deep channels	0.030-0.035
Sides, clean, gravel bottom	0.025-0.030
Sides, clean, cobble bottom	0.030-0.040
<b>Open channel, dragline excavated or dredged</b>	
No vegetation	0.028-0.033
Light brush on banks	0.035-0.050
<b>Open channel, rock</b>	
Based on design section	0.035
Based on actual mean section	
- Smooth and uniform	0.035-0.040
- Jagged and irregular	0.040-0.045
<b>Open channel not maintained, weeds and brush uncut</b>	
Dense weeds, high as flow depth	0.08-0.12
Clean bottom, brush on sides	0.05-0.08
Clean bottom, brush on sides, highest stage of flow	0.07-0.11
Dense brush, high stage	0.10-0.14
<b>Roadside ditch, swale, depth of flow up to 0.7 ft</b>	
Bermuda grass, Kentucky bluegrass, buffalo grass:	
- Mowed to 2 in.	0.045-0.07
- Length 4 to 6 in.	0.05-0.09
Good stand, any grass:	
- Length about 12 in.	0.09-0.18
- Length about 24 in.	0.15-0.30
Fair stand, any grass:	
- Length about 12 in.	0.08-0.14
- Length about 24 in.	0.13-0.25
<b>Roadside ditch, swale, depth of flow 0.7-1.5 ft</b>	
Bermuda grass, Kentucky bluegrass, buffalo grass:	
- Mowed to 2 in.	0.035-0.05
- Length 4 to 6 in.	0.04-0.06
Good stand, any grass:	
- Length about 12 in.	0.07-0.12
- Length about 24 in.	0.10-0.20
Fair stand, any grass:	
- Length about 12 in.	0.06-0.10
- Length about 24 in.	0.09-0.17

**Table 2-4: Typical Values of Manning's "n" Coefficients**

Table 2-4 cont.

Description	Typical Values
<b>Minor Streams</b>	
Fairly regular section:	
- Some grass and weeds, little or no brush	0.030-0.035
- Dense growth of weeds, depth of flow materially greater than weed height	0.035-0.05
- Some weeds, light brush on banks	0.04-0.05
- Some weeds, heavy brush on banks	0.05-0.07
- Some weeds, dense willows on banks	0.06-0.08
- For trees within channel, with branches submerged at high stage, increase all values above by:	0.01-0.10
<b>Mountain streams, no vegetation in channel, steep banks</b>	
Bottom of gravel, cobbles and few boulders	0.04-0.05
Bottom of cobbles, with large boulders	0.05-0.07
<b>Floodplains (adjacent to natural streams):</b>	
Pasture, no brush:	
- Short grass	0.030-0.035
- High grass	0.035-0.05
Cultivated areas:	
- No crop	0.03-0.04
- Mature row crops	0.035-0.045
- Mature field crops	0.04-0.05
Heavy weeds, scattered brush	0.05-0.07
Light brush and trees:	
- Winter	0.05-0.06
- Summer	0.06-0.08
Medium to dense brush:	
- Winter	0.07-0.11
- Summer	0.10-0.16
<b>Major streams (surface width at flood stage more than 100 ft)</b>	0.028-0.033
<b>Brass pipe, smooth</b>	0.009-0.013
<b>Steel</b>	
Lockbar and welded	0.010-0.014
Riveted and spiral	0.013-0.017
<b>Cast iron pipe</b>	
Coated	0.010-0.014
Uncoated	0.011-0.016
<b>Wrought iron pipe</b>	
Black	0.012-0.015
Galvanized	0.013-0.017
<b>Corrugated metal pipe</b>	
Subdrain	0.012-0.014
Riveted CSP	0.024-0.027
Helical CSP	0.011-0.027

**Table 2-4 cont.**

<b>Description</b>	<b>Typical Values</b>
Structural Plate	0.024-0.033
Spiral Rib Plate	0.012-0.013
<b>Lucite pipe</b>	0.008-0.010
<b>Glass lined pipe</b>	0.009-0.013
<b>Cement or cement lined pipe</b>	
Neat surface	0.010-0.013
Mortar	0.011-0.015
<b>Concrete pipe</b>	
Culvert, straight and free of debris	0.010-0.013
Culvert with bends, connections and some debris	0.011-0.015
Finished	0.011-0.015
Sewer with manholes, inlet, etc., straight	0.013-0.017
Unfinished, steel form	0.012-0.014
Unfinished, smooth wood form	0.012-0.016
Unfinished, rough wood form	0.015-0.020
<b>Polyvinyl Chloride pipe</b>	0.010-0.015
<b>Polyethylene pipe</b>	
Corrugated	0.021-0.030
Corrugated, smooth interior	0.010-0.015
Smooth wall	0.010-0.015
<b>Wood Conduit</b>	
Stave	0.010-0.014
Laminated, treated	0.015-0.020
<b>Clay pipe</b>	
Common drainage tile	0.011-0.017
Vitrified sewer	0.011-0.017
Vitrified sewer with manhole, inlet, etc.	0.013-0.017
Vitrified subdrain with open joint	0.014-0.018
<b>Brickwork Conduit</b>	
Glazed	0.011-0.015
Lined with cement mortar	0.012-0.017
<b>Sanitary sewers coated with sewage slimes, with bends and connections</b>	0.012-0.016
<b>Paved invert, sewer, smooth bottom</b>	0.016-0.020
<b>Rubble masonry, cemented</b>	0.018-0.030

Modified from Advanced Drainage System, Technical Notes 2.120, 1997

Assumptions that attend this simplified form of Manning's kinematic solution are:

- (1) shallow steady uniform flow
- (2) constant intensity of rainfall excess (that part of a rain available for runoff)
- (3) rainfall duration of 24 hours
- (4) minor effect of infiltration on travel time

Rainfall depth can be obtained from IDF curves representative of the project location.

The rainfall intensity in the Izzard formula may be estimated as follows:

- (1) assume  $t_c$
- (2) determine the intensity from the appropriate IDF curve
- (3) calculate  $t_c$  from the Izzard formula
- (4) Iterate steps 1 through 3 until the estimated value of  $t_c$  converges with the calculated value

After a maximum of 300 feet, sheet flow usually becomes shallow concentrated flow. The average velocity for shallow concentrated flow can be determined from Figure 2-3, in which average velocity is a function of watercourse slope and type of channel. After determining average velocity in Figure 2-3, use Equation 2.9 to estimate travel time for the shallow concentrated flow segment.

Open channel flow is flow that is confined by sidewalls, natural or constructed, and free to travel under the influence of gravity. When runoff flows in an open channel or pipe, the length of the channel or pipe and the velocity is used to determine time of concentration,  $t_c$ , for that portion of the watershed. The following Manning's equation may be used to determine the average velocity of open channel flow.

Manning's equation is

$$V = \frac{1.49 r^{2/3} s^{1/2}}{n} \quad \text{Equation 2-8}$$

Where:

- $V$  = average velocity, ft/sec
- $r$  = hydraulic radius in feet and is equal to the cross section area of the flow divided by the wetted perimeter,  $ft^2/P_w$
- $P_w$  = wetted perimeter, ft
- $s$  = slope of the hydraulic grade line (channel slope), ft/ft
- $n$  = Manning's roughness coefficient for open channel flow



Then, the travel time  $T_t$  can be estimated by:

$$T_t = \frac{L}{3600V} \quad \text{Equation 2-9}$$

Where:

- $T_t$  = travel time, min
- $L$  = flow length, ft
- $V$  = velocity, ft/sec

### Application of the Rational Method

In urban areas, the drainage area usually consists of subareas of different surface characteristics with different runoff coefficients. The peak rate of total drainage area runoff can be computed by the following composite analysis of the subareas:

$$Q_p = i \sum_{j=1}^n C_j A_j \quad \text{Equation 2-10}$$

Where:

- $Q_p$  = peak rate of flow, cfs
- $C_j$  = runoff coefficient for  $j^{\text{th}}$  subarea
- $A_j$  = the area for  $j^{\text{th}}$  subarea in acres
- $n$  = the number of subareas draining into the collection point

### The SCS TR-55 Method

In 1964, the United States Soil Conservation Service (SCS) developed a computer program for watershed modeling. That watershed model was presented in Technical Release 20 (TR-20). The model is used for watershed evaluation and flood plan studies. To estimate runoff and peak rates of flow in small watersheds, a simplified method was developed by SCS and presented in Technical Release 55 (TR-55). It can be downloaded @ [www.wcc.nrcs.usda.gov/water/quality/common/TR55/TR55.html](http://www.wcc.nrcs.usda.gov/water/quality/common/TR55/TR55.html). For small watersheds, stream flow records are often unavailable. Even when stream flow records are available, urbanization may cause inaccurate statistical analysis. The TR-55 method allows development of hydrologic models using watershed characteristics to estimate peak discharge from that watershed.

The TR-55 model begins with a rainfall amount uniformly imposed on a watershed for a twenty-four hour distribution period. Twenty-four hours was used because of the availability of daily rainfall data that could be used to estimate twenty-four hour rainfall amounts.

Rainfall is converted to mass rainfall using a runoff curve number (CN). TR-55 developed runoff curve numbers based upon watershed characteristics including soil type, type and amount of plant cover, amount of impervious area, runoff interception and surface storage. Runoff is then transformed into a hydrograph using a graphical or tabular computation method. The result is a peak discharge or design flow that can be used for drainage structure design.

TR-55 can be used for any location in the United States. It provides a nationally consistent method of determining peak flow and can be used as a check of peak flow computations made by other methods. If major discrepancies are found, a more thorough evaluation of the computations may be warranted.

Following are the steps necessary to determine a peak flow rate using the TR-55 Method.

Step 1. Determine the Area of the watershed basin as discussed earlier in this chapter.

Step 2. Determine the Hydrologic Soil Group (HSG) of the shed area.

Soils are classified into hydrologic soil groups to indicate the rate of infiltration and the rate at which water moves within the soil. HSG's are defined by SCS in TR-55 as follows:

Group A soils have low runoff potential and high infiltration rates even when thoroughly wetted. They consist chiefly of deep, well to excessively drained sands or gravels and have a high rate of water transmission (greater than 0.30 in/hr).

Group B soils have moderate infiltration rates when thoroughly wetted and consist chiefly of moderately deep to deep, moderately well to well drained soils with moderately fine to moderately coarse textures. These soils have a moderate rate of water transmission (0.15-0.30 in/hr).

Group C soils have low infiltration rates when thoroughly wetted and consist chiefly of soils with a layer that impedes downward movement of water and soils with moderately fine to fine texture. These soils have a low rate of water transmission (0.05-0.15 in/hr).

Group D soils have high runoff potential. They have very low infiltration rates when thoroughly wetted and consist chiefly of clay soils with a high swelling potential, soils with a permanent high water table, soils with a clay pan or clay layer at or near the surface, and shallow soils over nearly impervious material. These soils have a very low rate of water transmission (0-0.05 in/hr).

Step 3. Determine the type of cover found in the shed area.

Cover types can be determined by field observation, aerial photograph, or land use maps.

Step 4. Determine the Curve Number (CN) for the watershed area.

#### **SCS Runoff Curve Number Method**

The SCS Runoff Curve Number (CN) method is described in detail in National Engineering Handbook, Section 4 (SCS 1985) and is calculated as follows:

$$Q = \frac{(P-I_a)^2}{(P-I_a)+S} \quad \text{Equation 2-11}$$

Where:

Q = runoff, in

P = rainfall, in

S = potential maximum retention after runoff begins, in

$I_a$  = initial abstraction, in

Initial abstraction ( $I_a$ ) is the total of all losses before runoff begins. It includes water retained in surface depressions, water intercepted by vegetation, evaporation and infiltration.  $I_a$  is highly variable but generally is correlated with soil and cover parameters. Through studies of many small agricultural watersheds,  $I_a$  was found to be approximated by the following empirical equation:

$$I_a = 0.2S \quad \text{Equation 2-12}$$

By removing  $I_a$  as an independent parameter, this approximation allows use of a combination of S and P to produce a unique runoff amount, substituting equation 2.12 into equation 2.11 gives

$$Q = \frac{(P-0.2S)^2}{(P+0.8S)} \quad \text{Equation 2-13}$$

S is related to the soil and cover conditions of the watershed through the CN. CN has a range of 0 to 100, and S is related to CN by

$$S = \frac{1000}{CN} - 10 \quad \text{Equation 2-14}$$

TR-55 provides tabular solutions for CN for each cover type, hydrologic condition and hydrologic soil group.

Upon determination of CN for each cover type, hydrologic condition and hydrologic soil group, calculate the weighted CN for the total watershed area.

$$\text{CN (area}_1\text{)} \times \% \text{ of shed area} = \text{CN}_1$$

$$\text{CN (area}_2\text{)} \times \% \text{ of shed area} = \text{CN}_2$$

$$\text{CN (area}_3\text{)} \times \% \text{ of shed area} = \text{CN}_3$$

Step 5. Determine Time of Concentration,  $t_c$ .

The time of concentration (see Equation 2-5) is the summation of the travel time through each consecutive segment of the watershed area.

Travel time for sheet flow, shallow concentrated flow and open channel flow can be calculated as discussed earlier in this chapter.

Step 6. Determine initial abstraction,  $I_a$ .

$I_a$  is dependent upon the Curve Number only. Using the CN found in Step 3, the initial abstraction  $I_a$  is found in tabular form in TR-55.

Step 7. Compute  $I_a/P$

$I_a$  was determined in Step 6. P is the highest peak discharge for the watershed. The highest peak discharges from small watersheds usually occur during intense, brief rainfalls that may be distinct events or part of a longer storm. These intense rainstorms do not usually extend over a large area and intensities vary greatly.

Different rain fall distributions can be developed for each watershed to emphasize the critical rainfall duration for the peak discharges. However, to avoid the use of a different set of rainfall intensities for each drainage area size, it is common practice in rainfall-runoff analysis to develop a set of synthetic rainfall distributions.

For the small size drainage areas, a storm period of 24 hours is appropriate for determining runoff volumes, even though 24 hours is a longer period than needed to determine peak runoff. TR-55 provides synthetic rainfall distribution with various intensities. Rainfall with 24 hour duration and various intensities can also be obtained from the National Oceanic and Atmospheric Administration or more local weather or water resource agencies.

Step 8. Determine the type of rainfall distribution.

A geographic depiction of rainfall distribution types is provided in TR-55. Types I, IA, II and III are dependent upon storm intensity.

Step 9. Graphically determine unit peak discharge,  $q_u$

In steps 5, 6, 7 and 8 rainfall distribution type, Time of Concentration and  $I_a/P$  have been determined. With these parameters, TR-55 provides graphical methods of determining the peak unit discharge  $q_u$  (See Figure 2-4).

Step 10. Calculate peak discharge.

Peak discharge  $Q_p$  is calculated using Equation 2-15.

$$Q_p = q_u A_m Q F_p \quad \text{Equation 2-15}$$

Where:

$Q_p$  = peak discharge, cfs

$q_u$  = unit peak discharge, cfs per square mile per in

$A_m$  = drainage area, square miles

$Q$  = direct runoff, in

$F_p$  = pond or swamp adjustment factor

Unit peak discharge,  $q_u$ , was determined in Step 9. Drainage basin Area  $A$  (watershed area) was determined in Step 1. Direct runoff,  $Q$ , is determined by Equation 2.11 and 2.13. Pond or swamp adjustment factor,  $F_p$ , adjusts for the total area of ponding throughout the watershed. TR-55 provides a Table giving  $F_p$  for various percentages of the watershed found by observation to be pond areas.

## Hydraulic Engineering Center Computer Modeling Method

For large, complex watersheds and for important or sensitive culvert installations, it may be necessary to utilize a sophisticated computer solution for determining runoff hydrographs.

The U.S. Army Corps of Engineers, Hydraulics Engineering Center, has developed a set of hydraulic models for use in watershed management. HEC-HMS (Hydraulic Engineering Center-Hydrologic Modeling System) is widely used and accepted to model watershed hydrology. It is capable of simulating a large number of separate sub-shed areas, actual storm events, infiltration methods and methods for routing flows from point to point within the watershed. The HEC-HMS software can be downloaded at [www.hec.usace.army.mil/](http://www.hec.usace.army.mil/).

The U.S. Army Corps of Engineers HEC-RAS (Hydraulics Engineer Center-River Analysis System) is a computer program which determines water evaluations in open channels under steady flow conditions. It has culvert routines and when used with the peak flow from the runoff hydrograph (from HEC-HMS), it can be used to validate a previously estimated culvert size and slope. The HEC-RAS software can be downloaded at [www.hec.usace.army.mil/](http://www.hec.usace.army.mil/).

## Design of Culverts

The basis for conduit design is the energy equation for conduit flows. At a point along any reach of pipe, the total energy head can be expressed as the sum of the elevation head ( $Z$ ), the pressured head ( $P/\gamma$ ) and the velocity head ( $\frac{V^2}{2g}$ ). The Energy Grade Line represents the profile plot of the total energy head along the concerned pipeline. The Hydraulic Grade Line represents the profile plot of the piezometric head (the sum of  $Z + P/\gamma$ ) along the concerned pipeline. The energy conservation equation between Points A and B along a pipeline shown in Figure 2.4 can be expressed as:

**Figure 2-4**

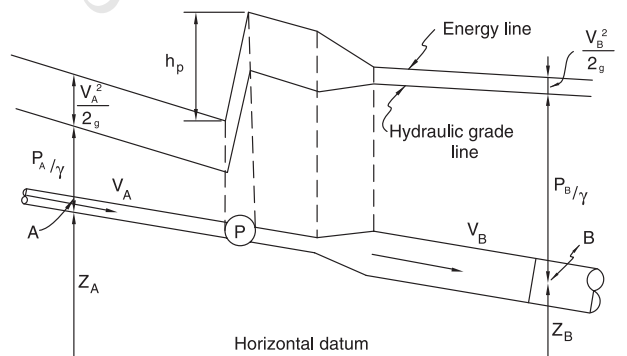

**Figure 2-4: Energy Grade Line and Hydraulic Grade Line along a Pipeline**

$$\frac{P_A}{\gamma} + Z_A + \alpha_A \frac{V_A^2}{2g} = \frac{P_B}{\gamma} + Z_B + \alpha_B \frac{V_B^2}{2g} + \sum h_L \quad \text{Equation 2-16}$$

Where:

$\frac{P_A}{\gamma}$  = pressured head @ Section A

$Z_A$  = Elevation head at Section A

$\alpha_A \frac{V_A^2}{2g}$  = Kinetic Energy head with adjusting factor  $\alpha$   
due to non-uniform velocity distribution at Section A

$\Sigma h_L$  =  $\Sigma h_f + \Sigma h_{ml}$  = Sum of the major and minor losses

$\Sigma h_f$  = Sum of major loss due to friction between Sections A and B

$\Sigma h_{ml}$  = Sum of all the minor losses between Sections A and B

The major friction loss  $h_f$  can be calculated by the Darcy-Weisbach Equation:

$$h_f = f \frac{L V^2}{D 2g} \quad \text{Equation 2-17}$$

Where:

$f$  = Friction factor

$L$  = Length of pipe flow between Sections A and B, ft

$D$  = Diameter of pipe, ft

$V$  = Average velocity, ft/sec

$g$  = Acceleration due to gravity ft/sec/sec

Friction factor,  $f$ , is a function of Reynolds number  $R$  and relative Roughness coefficient.

The friction factor,  $f$ , can be obtained through the Moody's diagram, Figure. 2.5.

**Figure 2-5**

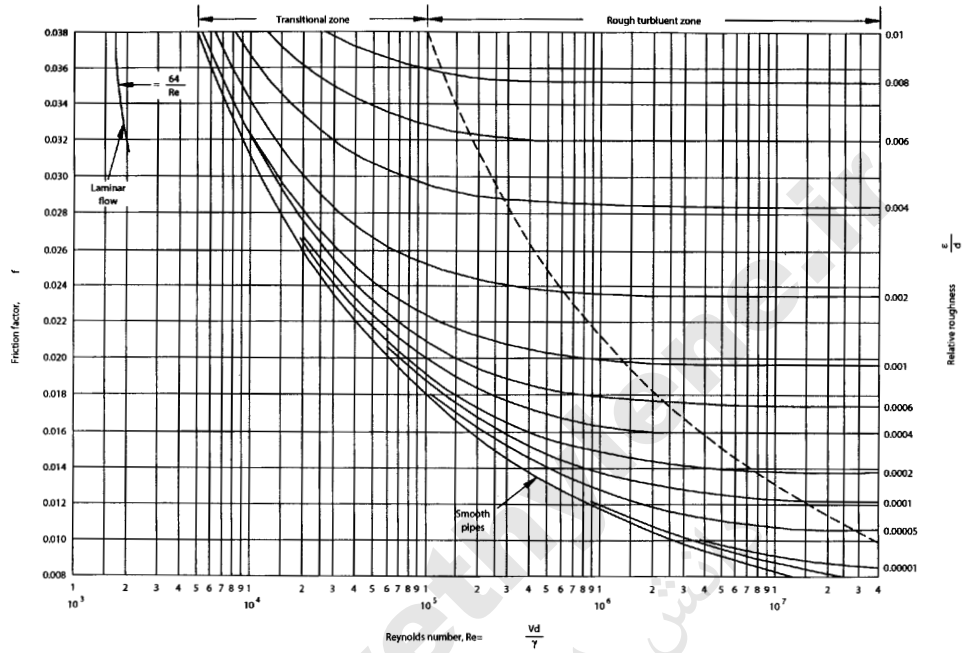

**Figure 2-5: Moody's Diagram**

The minor losses, which include entrance, contraction, expansion, bends and other fittings can be calculated by the equation:

$$h_{ml} = K \frac{V^2}{2g} \quad \text{Equation 2-18}$$

Where:

$h_{ml}$  = minor head loss

$K$  = Sum of loss coefficients which can be obtained from Table 2.5

$V$  = Average inflow velocity for the concerned transition or fittings

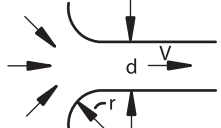
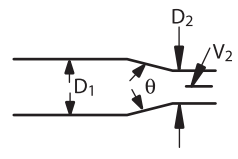
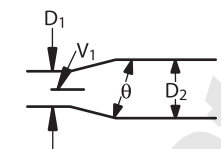
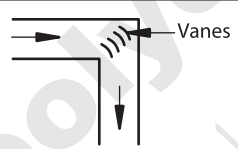
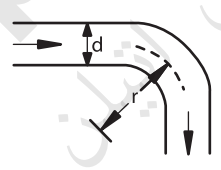

**Table 2-5**

Description	Sketch	Additional Data	K
Pipe entrance $h_L = K_e V^2/2g$		$r/d$	$K_e$
		0.0	0.50
		0.1	0.12
		>0.2	0.03
Contraction $h_L = K_C V_2^2/2g$		$D_2/D_1$	$K_C$
			$\theta = 180^\circ$
		0.0	0.50
		0.20	0.49
		0.40	0.42
		0.60	0.32
		0.80	0.18
		0.90	0.10
Expansion $h_L = K_E V_1^2/2g$		$D_1/D_2$	$K_E$
			$\theta = 180^\circ$
		0.0	1.00
		0.20	0.92
		0.40	0.72
		0.60	0.42
		0.80	0.16
90° miter bend		Without vanes	$K_b = 1.1$
		With vanes	$K_b = 0.2$
90° smooth bend		$r/d$	$K_b = 0.35$
		1	0.19
		2	0.16
		4	0.21
		6	0.28
		8	0.32
		10	
Threaded pipe fittings	Globe valve – wide open Angle valve – wide open Gate valve – wide open Gate valve – half open Return bend Tee straight-through flow side-outlet flow 90° elbow 45° elbow		$K_v = 10.0$
			$K_v = 5.0$
			$K_v = 0.2$
			$K_v = 5.6$
			$K_b = 2.2$
			$K_t = 0.4$
			$K_t = 1.8$
			$K_b = 0.9$
			$K_b = 0.4$

**Table 2-5: Loss coefficients for various transitions and fittings**

## Hydraulics of Culverts

When stream channels pass under transportation facilities, such as highways or roadways, railroad embankments, irrigation canals or other geographical obstructions, a drainage structure is required to pass the water under the obstruction. The two common types of structures are open channels with bridges and culverts.

Culverts are designed to pass the design flow without overtopping the surrounding embankment and without erosion of the fill (or embankment) at either the upstream or downstream end of the culvert.

The flow in a culvert is a function of the following geometric variables: Cross-sectional size and shape (circular, rectangular or other), slope  $S$ , length  $L$ , roughness  $n$  and entrance and exit hydraulic properties. Flow in a culvert may occur as an open channel flow, or as completely full pipe flow, or as a combination of both. The headwater depth  $H_w$  and tailwater depth  $T_w$  are the two major factors that dictate whether the culvert flows partially or completely full.

Culvert flow may be controlled at the inlet or the outlet. Pressure and the nature of the flow, subcritical or supercritical, play an important role in determining whether the inlet or outlet controls the flow, and consequently, the hydraulic capacity of the culvert.

### Inlet Control

Inlet control of flow occurs when the culvert barrel is capable of conveying more flow than the inlet will accept. The control section for inlet control is located at the entrance of the culvert. Critical depth occurs at or near the entrance, and the flow regime immediately downstream is supercritical flow. The hydraulic characteristics downstream of the inlet control section do not affect the culvert capacity. The inlet geometry (barrel shape, cross-sectional area and the inlet edge) and headwater depth play the major role in inlet control. Figure 2.6 shows the possible types of inlet control flows.

**Figure 2-6**

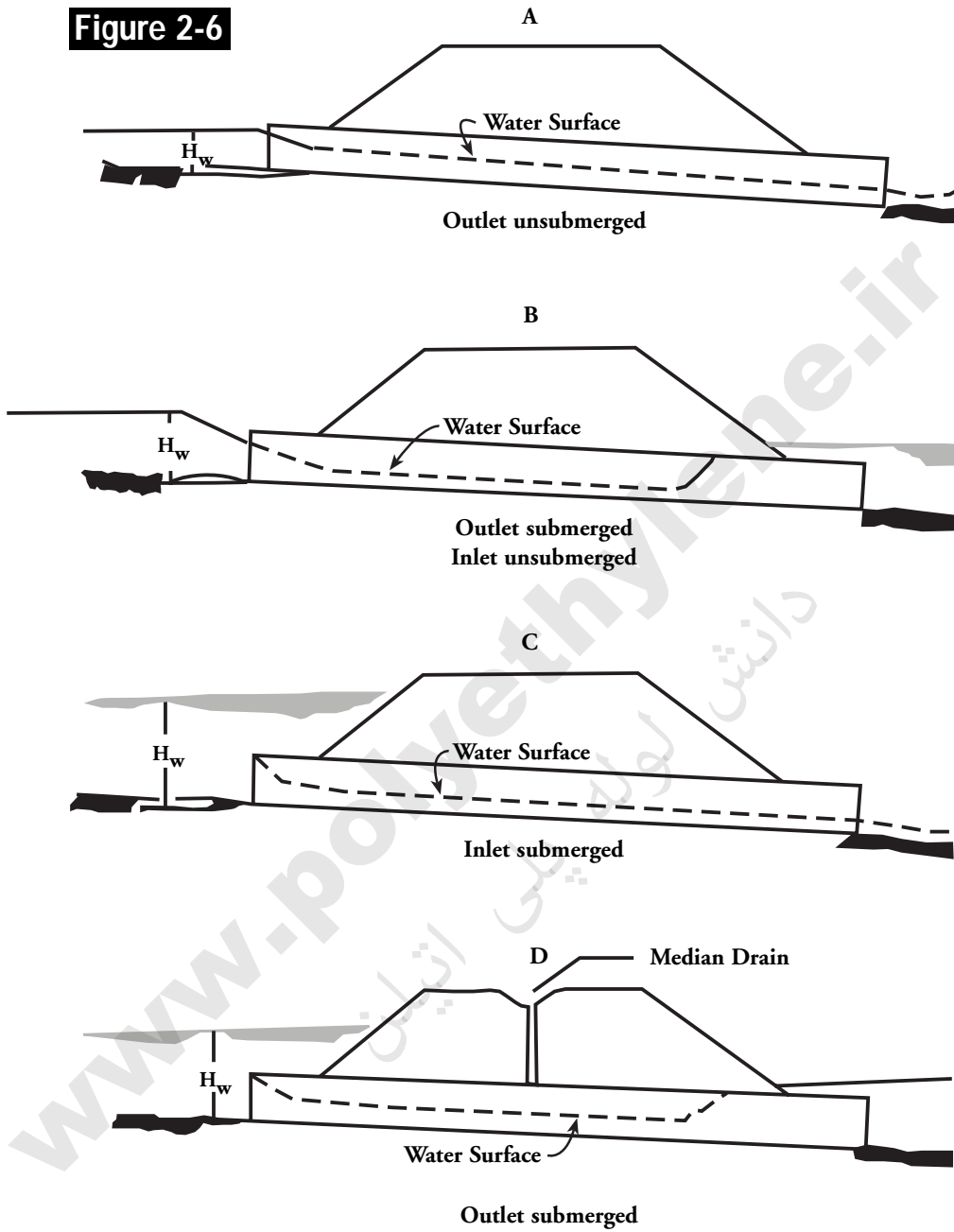

**Figure: 2-6: Types of Inlet Control**

### Outlet Control

Outlet control flow occurs when the culvert barrel is not capable of conveying as much flow as the inlet opening will accept. The control section for outlet control flow in a culvert is located at the barrel exit or further downstream. Either subcritical or pressure flow exists in the culvert barrel under the outlet control situations. All of the geometric and hydraulic characteristics of the culvert play a role in determining its flow capacity. These characteristics include all the governing factors for inlet control, tailwater depth  $T_w$ , slope  $S$ , roughness  $n$ , and length of the culvert barrel. Figure 2.7 shows the possible types of outlet control flows.

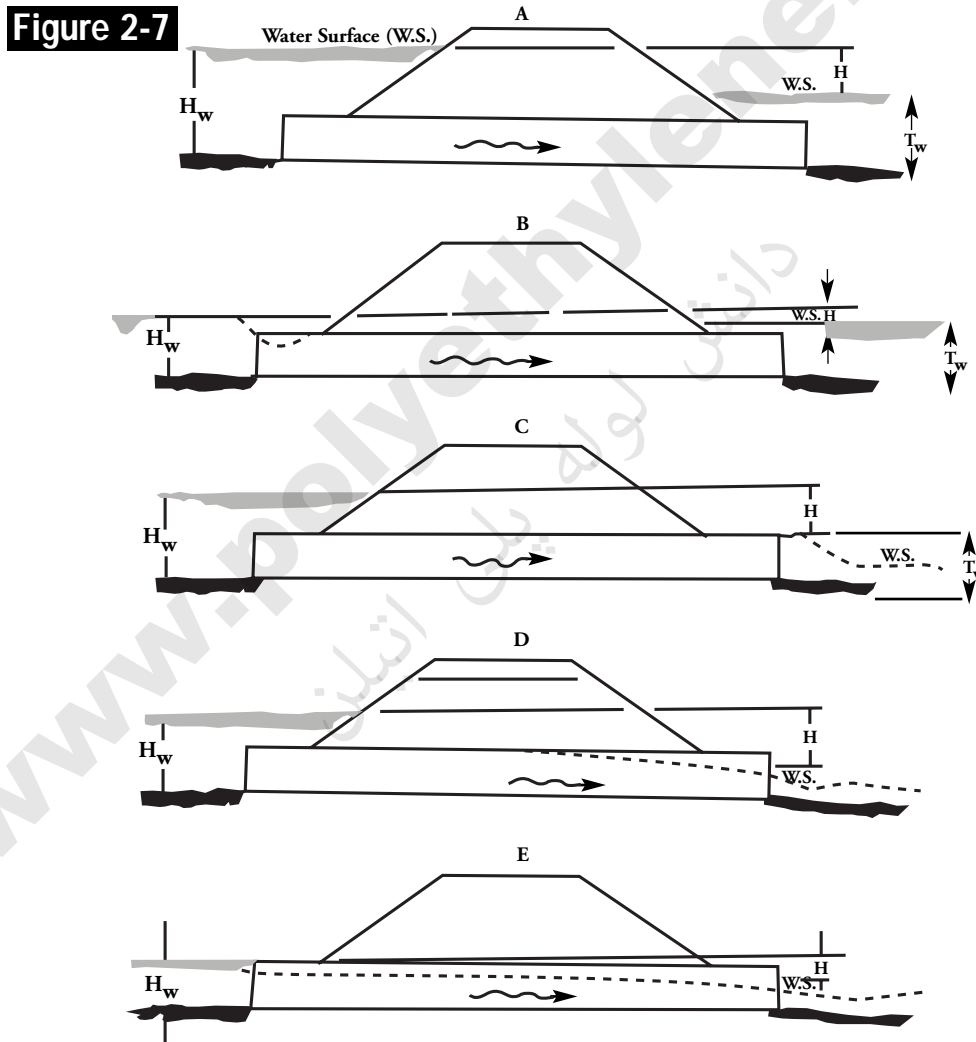

Figure: 2-7: Types of Outlet Control (HDS No. 5)

## Determination of Culvert Capacity

There are six basic culvert flow types. Three of these flow types occur under unsubmerged entrance conditions and three occur under submerged entrance conditions, all six are described below. Following each culvert type is an illustration depicting flow of that type. Following the illustration is the discharge formula for that culvert type.

### Unsubmerged Entrance

Type 1: Steep slope flowing partially full, discharge depth less than critical depth, therefore inlet control exists.

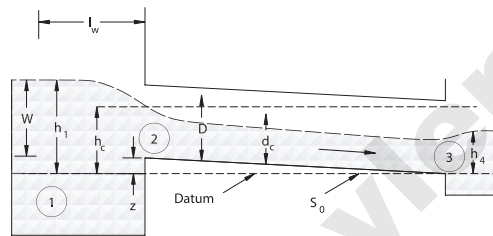

$$Q = C_d A_c \sqrt{2g \left[ H_w + \frac{V_1^2}{2g} - d_c - h_{1,2} \right]} \quad \text{Equation 2-19}$$

Where:

$C_d$  = discharge coefficient

$H_w$  = headwater depth, ft

$V_1$  = approaching velocity, ft/sec

$d_c$  = critical flow depth, ft

$h_{1,2}$  = head loss from Section 1 to Section 2, ft

$A_c$  = flow area at critical depth, ft<sup>2</sup>

Type 2: Shallow slope flowing partially full, discharge depth greater than critical depth, therefore outlet control exists, even though tail water depth is less than critical depth.

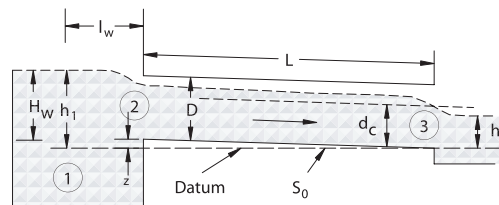

$$Q = C_d A_c \sqrt{2g H_w + Z + \frac{V_1^2}{2g} - d_c - h_{1,2} - h_{2,3}} \quad \text{Equation 2-20}$$

Where:

$h_{2,3}$  = head loss from cross section 2 to 3, ft

Type 3: Shallow slope flowing partially full discharge depth greater than critical depth therefore outlet control exists.

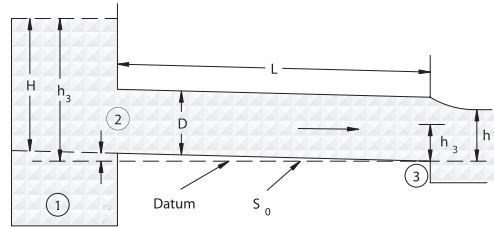

$$Q = C_d A_3 \sqrt{2gH_w + Z + \frac{V_i^2}{2g} - h_3 - h_{1,2} - h_{2,3}} \quad \text{Equation 2-21}$$

Where:

$A_3$  = flow area at cross section 3, ft<sup>2</sup>

$H_3$  = flow depth at cross section 3, ft

### Submerged Entrance

Type 4: Culvert flowing full, discharge is submerged, discharge depth greater than critical depth, therefore outlet control exists.

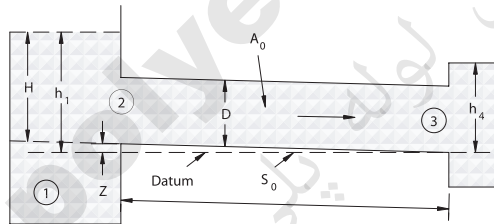

$$Q = C_d A_o \sqrt{\frac{2g(H_w + Z - T_w)}{1 + 29n^2 L/R_o^{4/3}}} \quad \text{Equation 2-22}$$

Where:

$T_w$  = tailwater flow depth, ft

$n$  = Manning's roughness coefficient

$L$  = length of culvert, ft

$A_o$  = cross sectional area of full culvert flow, ft<sup>2</sup>

$R_o$  = hydraulic radius of full culvert flow, ft

Type 5: Culvert flowing full discharge not submerged but outfall greater than critical depth, therefore outlet control exists.

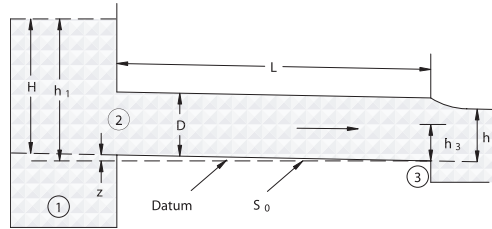

$$Q = C_d A_o \sqrt{\frac{2g(H_w + Z - D)}{1 + 29n^2 L/R_o^{4/3}}} \quad \text{Equation 2-23}$$

Where:

D = diameter of culvert, ft

Type 6: Culvert flowing part full, discharge depth less than critical depth, therefore inlet control exists.

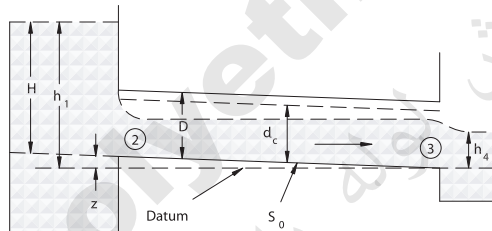

$$Q = C_d A_o \sqrt{2gH_w + Z + \frac{V_i^2}{2g} - \frac{D}{2}} \quad \text{Equation 2-24}$$

To determine the type of flow for a given culvert configuration, the following steps are recommended:

1. Determine the design flow for the culvert location, as discussed earlier in this chapter.
2. Using Manning's equation and the design flow from Step 1, estimate the size of the culvert.
3. Determine the critical depth,  $d_c$ , and the normal depth,  $d_n$ , for the culvert. Normal depth is the depth at which uniform flow will occur. Normal depth may be determined by the Manning equation (Equation 2.8) and substituting expressions involving diameter for A and R.

Critical depth is defined as the depth for which specific energy is a minimum. Specific energy is the sum of the depth and the velocity head. Flow at critical depth can be expressed by Equation 2.25.

$$\frac{Q^2}{g} = \frac{a^3}{T} \quad \text{Equation 2-25}$$

Where:

- Q = flow, cfs
- a = area of the flow stream, ft<sup>2</sup>
- T = top width of the flow stream, ft

Handbook of Hydraulics, King & Brater has tabular solutions for  $d_c$ .

4. Determine the depth of the tailwater flow in the channel downstream of the culvert,  $T_w$ .
5. Determine the type of culvert flow as follows:
  - If  $d_n < d_c$  and  $T_w < d_c$  then Type 1
  - If  $d_n > d_c$  and  $T_w < d_c$  then Type 2
  - If  $d_n > d_c$  and  $T_w > d_c$  then Type 3
6. Using the discharge equation for the identified type of flow, check the computed flow with the designed flow and then confirm the size of the pipe. If the discharge equation produces a different size culvert, repeat the trial.

Culvert Types 1 through 4 are usually not difficult to identify and classify during design. Types 5 and 6, however, can be difficult to identify. Bouthaine developed relationships for Type 5 and 6 culverts that are provided in Figures 2.8 and 2.9.

Figure 2.9 is used for circular sections. The procedure to determine Type 5 or 6 culvert is as follows:

1. Compute  $r/D$  and compute  $\frac{29n^2(h_1-Z)}{R_o^{4/3}}$  where  $r$  is the radius of the inlet edge and  $h_1$ , is the height of water at the inlet above the outlet.
2. Select Figure 2.9 corresponding to the appropriate  $r/D$ .



3. Plot the point defined by  $S_o$  and  $L/D$  for the culvert in Figure 2.9.
4. If the point plots to the right of the computed value of  $\frac{29n^2(h_1-Z)}{R_o^{4/3}}$  then the culvert is Type 5; if to the left, the culvert is Type 6.

### Hydraulic Design of Highway Culverts (HDS No. 5)

It is difficult to determine if the flow capacity of a culvert will be controlled by the culvert inlet (inlet control) or if the flow capacity will be controlled by the conditions of the barrel of the culvert (outlet control). The U.S. Department of Transportation, Federal Highway Administration (FHWA) developed a culvert design manual called the Hydraulic Design of Highway Culverts. It is FHWA Report No. FHWA-IP-85-15 HDS No. 5 and is often referred to as HDS-5.

This design manual utilizes a method of design that assists in determining whether a culvert will have inlet control or outlet control. By utilizing the HDS-5 Culvert Design Form, the type of culvert flow becomes clear and produces confidence that the culvert sizing is correct.

The HDS-5 design method uses a Culvert Design Form to walk the designer through a step-by-step process to determine upstream and downstream water elevations. Completing the Culvert Design Form is most easily accomplished using the charts, tables and monographs found in HDS-5. Stepping through the analysis required to complete the Culvert Design Form provides a thorough evaluation of the hydraulics of the culvert.

HDS-5 has a computer program associated with the design method referred to as HY8. HY8 FHWA Culvert Analysis (Version 6.1) is available electronically on line and can be downloaded from [www.fhwa.dot.gov/bridge/hydssoft.htm](http://www.fhwa.dot.gov/bridge/hydssoft.htm). HY8 can be a valuable design tool. However, the program is DOS based and is not particularly user friendly. Using HY8 efficiently requires experience with the program.

**Figure 2-8**

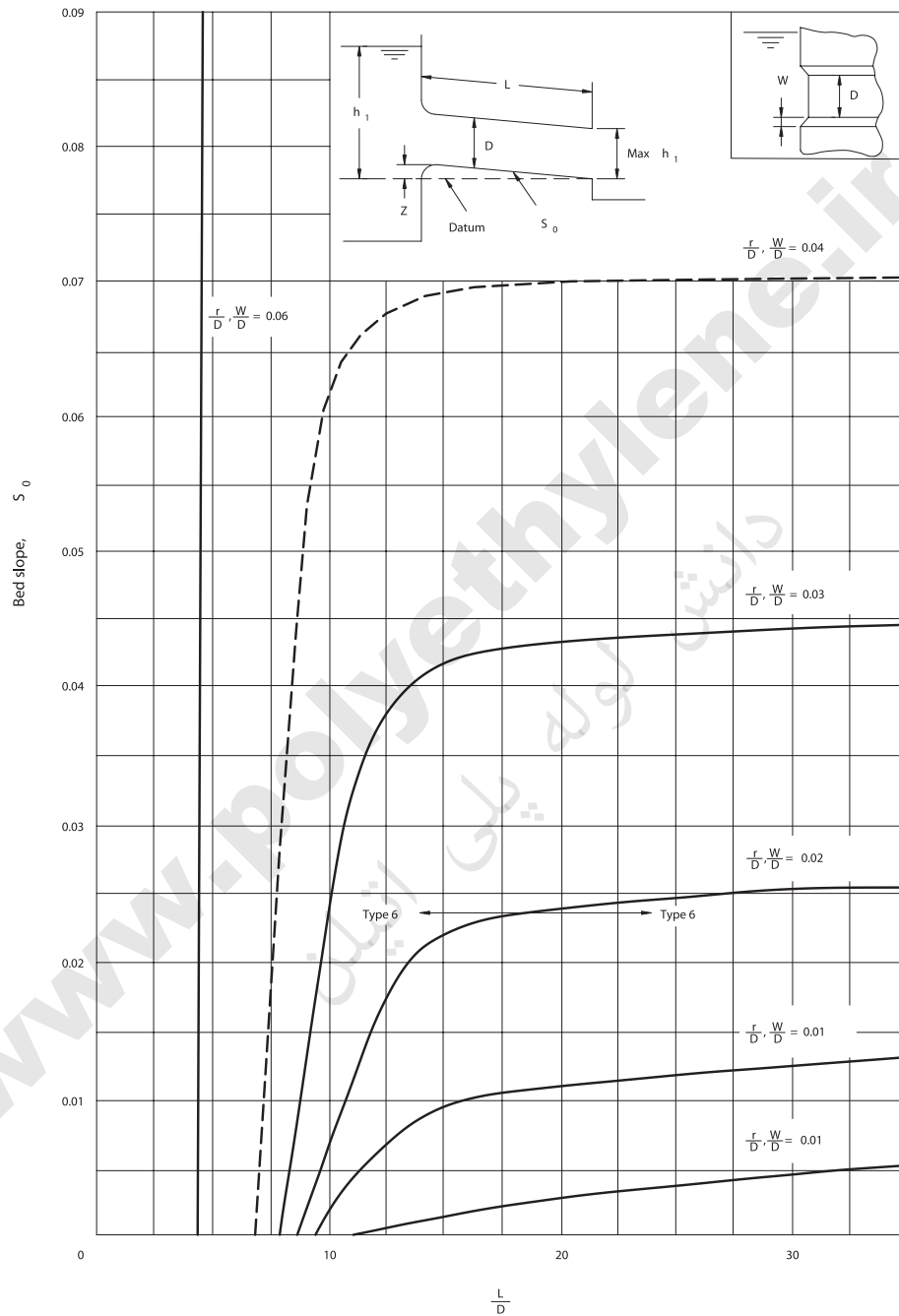

**Figure: 2-8: Smooth pipe or box sections**

**Figure 2-9**

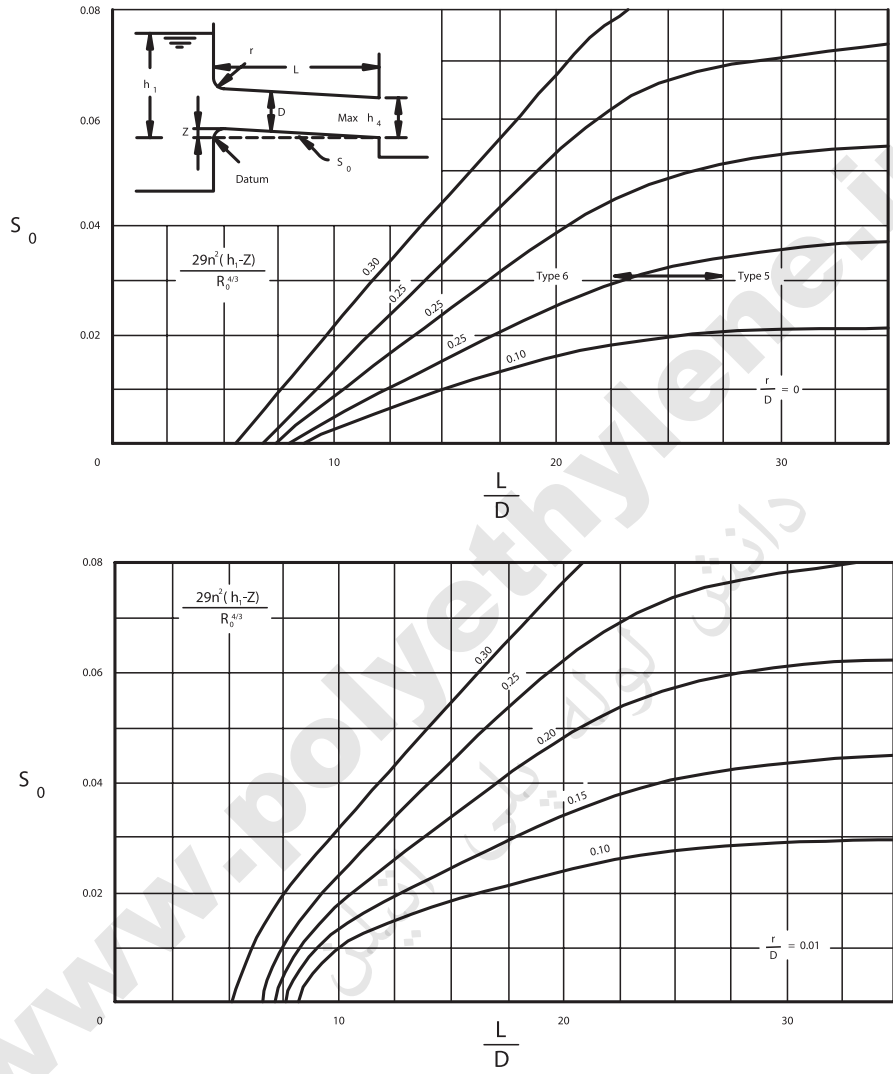

**Figure 2-9: Circular Sections**

**Figure 2-9**

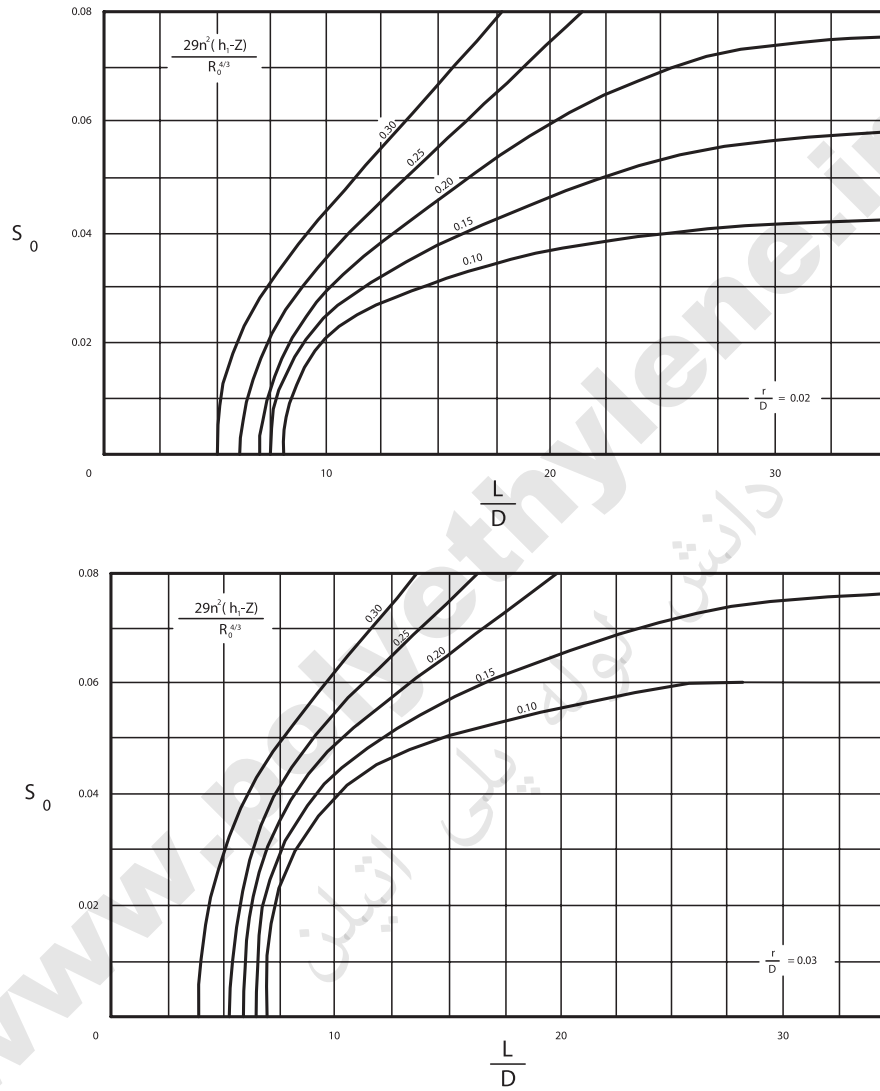

**Figure: 2-9: Circular Sections**

## Summary

Several design methods are available for determining design flow and drainage structure sizing. Many agencies have design requirements that are less general than those included herein. Refer to agency design standards for particular agency requirements. Based upon a review of agency requirements and appropriate engineering judgment regarding the particular watershed and drainage structure, the designer should select appropriate design methods.

Upon completion of a drainage conveyance facility design, careful consideration should be given to the proposed installed condition of the designed drainage facility (culvert or pipeline). For the completed design, evaluate inlet control versus outlet control, the installed capacity of the designed conveyance facility, headwater and tailwater elevations, and discharge velocity.

www.polyethylene.ir  
دانش لوله پلی اتیلن

## Bibliography

American Iron & Steel Institute, *Modern Sewer Design Handbook, 2nd Edition*, 1990.

P.B. Bediant and W.C. Huber, *Hydrology and Floodplain Analysis*, Addison-Wesley Publishing Co., 1988.

G.L. Bodthaines, *Measurement of Peak Discharge at Culverts by Indirect Method*, Techniques of Water Resources Investigations, U.S.G.S., Washington D.C., 1982.

R.L. Bras, *Hydrology and Introduction to Hydrologic Science*, Addison Wesley Publishing Co., 1990.

V.T. Chow, D.R. Maidment and L.W. Mays, *Applied Hydrology*, McGraw Hill Book Company, 1988.

Federal Highway Administration, U.S. Department of Transportation, *Hydraulic Design of Highway Culverts*, Report No. FHWA-IP-85, 15, HDS No. 5, 1985.

A.T. Hjelmfelt, Jr. and J.J. Cassidy, *Hydrology for Engineers and Planners*, Iowa State University Press, Ames, Iowa, 1975.

Hydrologic Engineering Center, *HEC-1 Flood Hydrograph Package User's Manual*, U.S. Army Corps of Engineers, Davis California, 1990.

D.M. Gray, Editor in Chief, *Handbook on the Principles of Hydrology*, National Research Council of Canada, 1970.

R.S. Gupta, *Hydrology and Hydraulic Systems*, Waveland Press, Inc., 1995.

T.V. Hromodke II, *Computer Methods in Urban Hydrology: Rational Methods and Unit Hydrograph Methods*, Lighthouse Publications, 1983.

King & Brater, *Handbook of Hydraulic*, McGraw-Hill, Inc., 1963.

R.K. Linsley, J.B. Franzini, *Water Resources Engineering*, McGraw Hill Book Company, 1964.

R.K. Linsley, Jr., M.A. Kohler and J.A.H. Paul Hus, *Hydrology for Engineers, 3rd Edition*, New York, McGraw Hill, Inc., 1982.

R.K. Linsley, J.B. Franzini, D.L. Freyberg and G. Tchobanoglous, *Water Resources Engineering, 4th Edition*, McGraw Hill, Inc., 1992.

R.H. McCuen, *A Guide to Hydrologic Analysis Using SCS Methods*, Prentice Hall, Inc. 1982.

R.H. McCuen, *Hydrologic Analysis and Design, 2nd Edition*, Prentice Hall, Inc., 1998.

National Engineering Handbook, Section, 1985.

O.E. Overton and M.E. Meadows, *Storm Water Modeling*, Academic Press, Inc., New York, 1976.

V.M. Ponce, *Engineering Hydrology Principles and Practices*, Prentice-Hall, Inc., 1989.

Portland Cement Association, *Handbook of Concrete Culvert Pipe Hydraulics*, printed by Portland Cement Association, 1964.

E.F. Shulz, *Problems in Applied Hydrology*, Water Resources Publications, Fort Collins, Colorado, 1976.

Uni-Bell PVC Pipe Association, *Handbook of PVC Pipe Design and Construction, 4th Edition*, 1991.

U.S. Department of Agriculture, Soils Construction Service, Engineering Division Technical Release 20, 1964.

U.S. Department of Agriculture, Soils Construction Service, Engineering Division Technical Release 55, 1986.

W. Viessman, Jr., and G.L. Lewis, *Introduction to Hydrology, 4th Edition*, Harper Collins College Publishers, 1996.

E.M. Wilson, *Engineering Hydrology*, MacMillan and Co. LTD., Great Britain, 1969.

Notes

[www.polyethylene.ir](http://www.polyethylene.ir)  
دانشگاه فوله پلی اتیلن